

FIRE/EXHAUST VALVE

Halton FDV

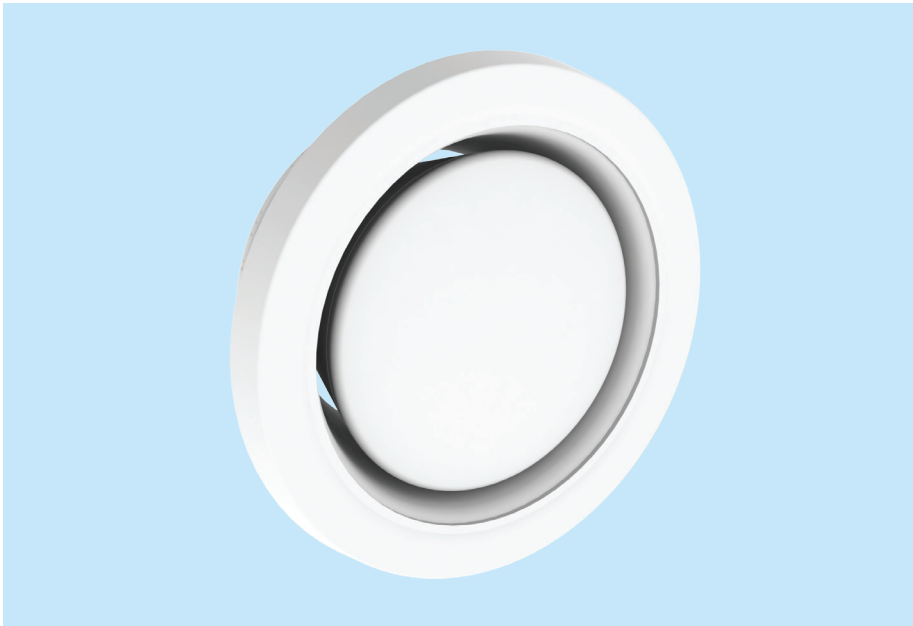

The Halton FDV, which has replaced the Halton FRH, is a circular fire valve, which combines an exhaust valve and fire damper for the ducts. FDV is designed to prevent fire and smoke from spreading in ventilation ducts.

The Halton FDV has two operation modes: normal and emergency.

In the normal mode the FDV acts as an exhaust valve. The valve throttles the exhaust air flow and attenuates the duct noise. The pressure drop is dependent on the position of the central cone. The desired exhaust rate is set during the balancing of the air flows in a ductwork system.

In the emergency mode the FDV acts as a fire damper. The fire damper contains an integral thermal fuse. This fuse responds to a rise in temperature, which causes a spring-actuated central cone to close. The thermal fuse is released at 72°C.

DIMENSIONS AND WEIGHT

NS	ØW	H	ØD
100	139	88	99
125	165	88	124
160	200	88	159
200	251	88	199

NS	Weight (kg)
100	0.40
125	0.53
160	0.72
200	1.03

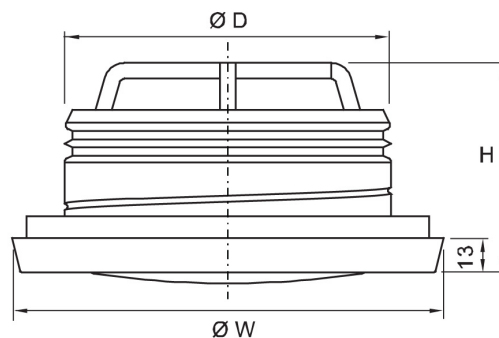

THE HVAC SHOP

The Halton FDV fire/exhaust valve offers the following advantages:

- Combines an exhaust valve and fire damper
- Prevents the spread of fire and flue gasses into ventilation ductwork
- Installation for plasterboard and concrete/masonry
- Adjustable air flow
- Specifically designed for round ducts
- Thermal fuse set at 72°C
- Supplied with an installation ring and spigot
- Manufactured in accordance with an ISO 9001 quality management system

FIRE/EXHAUST VALVE

Halton FDV

THE HVAC SHOP

MATERIAL AND FINISHING

Part	Material	Note
Collar	Steel	Epoxy painted
Central cone	Steel	Epoxy painted
Frame gasket	Polyurethane	
Fireproof gasket	Silicate	
Installation frame	Galvanised steel	
Melting fuse	Brass	

APPROVAL

Fire tested to BS 476:part 22: 1987 by the Loss Prevention Council, the subject of FIRTO Technical Evaluation No. TE 6643.

Complies with the Australian & NZ Building codes as an alternative solution (incorporating AS1682 as a guide line).

ADJUSTMENT

The valve is adjusted by rotating the central cone. Measure the opening (A) position (in mm) of the central cone. Set a probe inside the valve, and measure the differential pressure with a manometer. The air flow rate is calculated by using the formula below. After the adjustment, lock the central cone with the locking nut.

$$q_v = k * \sqrt{\Delta p_m}$$

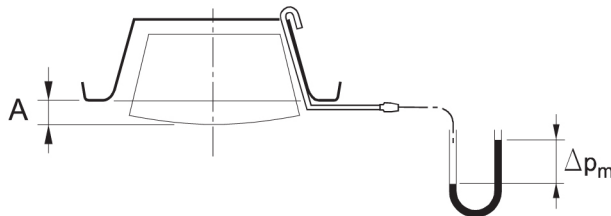

Verification as follows:

BRANZ Assessment FAR2687 dated 15 March 2006, BRANZ Fire Resistance Test FP2376 dated 31 July 1997, BRANZ Assessment FAR3668 dated 18 February 2011, and BRANZ Assessment FAR 97/1026 dated 10.01.1997. The results of test No. FP2376 confirm the plasterboard mounting system for the FRH will satisfy AS1530.4-1990 for 120 minutes.

(Please note that the Halton FDV supersedes the Halton FRH and URH-S models.)

Research reports PAL 3147 and PAL 2268 of the Fire Technology Laboratory of the Technical Research Centre of Finland.

Accessories

Installation Frame/Ring LF
Installation Collar IC

FDV Ø 100		FDV Ø 125		FDV Ø 160		FDV Ø 200	
A	k	A	k	A	k	A	k
-15	0.43	-15	0.65	-12	1.16	3	1.78
-12	0.63	-12	0.92	-9	1.51	6	2.46
-9	0.83	-9	1.22	-6	1.9	9	3.24
-6	1.02	-6	1.53	-3	2.31	12	3.97
-3	1.22	-3	1.84	0	2.75	15	4.69
0	1.42	0	2.17	3	3.25	20	5.88
3	1.65	3	2.52	6	3.73	25	6.95
6	1.88	6	2.83	9	4.22		
9	2.11	9	3.14	12	4.67		
12	2.33	12	3.46	15	5.12		
		15	3.77	18	5.58		

INSTALLATION

Halton FRH valves are supplied with full installation instructions for both walls and ceilings.

AIRFLOW ENGINEERING
THE HVAC SHOP

The One Stop Heating, Ventilation & Air Conditioning Shop
sales@thevacshop.co.nz | www.thevacshop.co.nz | sales@airflo.co.nz
Unit 2, 3 Langstone Lane, Northcote, Christchurch | +64 3 365 6278
The HVAC Shop is a company of Airflow Engineering (SI) Ltd