

# DATA SHEET



## Portable Floor Fan SPX500

Portable cooling fans provide quiet operation and a powerful, uniform distribution of air. The fans feature three speed settings, an adjustable lock in vertical tilt mechanism and a sturdy chrome finished tube frame.



This product may require some assembly.

### SPECIFICATIONS

o Portable Floor Fan SPX500
o Motor: 230-240VAC 50Hz 0.80 Amp 1350 RPM
o Total Motor Wattage: 180 watts
o Sound Pressure Level at 3m in dBA: 64 on high
o Impellor Construction: Aluminium
o Three-speed, push-button control, Fan has a standard three-prong electrical plug.
o Free Air Fan Performance Approx.: Low 1417 l/s Med 1867 l/s High 2367 l/s
o Impellor Diameter: 500mm diameter
o Built-in safety thermal fuse
o Adjustable Tilt Head

Features	Benefits
o 3 Speed control	o Enables speed selection
o Triangular base / U-base tube	o Sturdy and durable
o Adjustable lock in vertical tilt mechanism	o Easy positioning to direct airflow
o Full metal construction	o Will handle most environments and suit any décor
o Wall mounting brackets / Allows variety of mounting options	o Hang or sit it wherever it suits you for optimum performance
o 1 Year Warranty	

#### Parts List

1. Fan base tube
2. Metal blade
3. Fan head

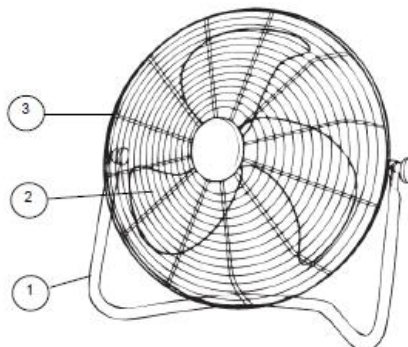

# DATA SHEET

## DIMENSIONS & ELECTRICAL DATA

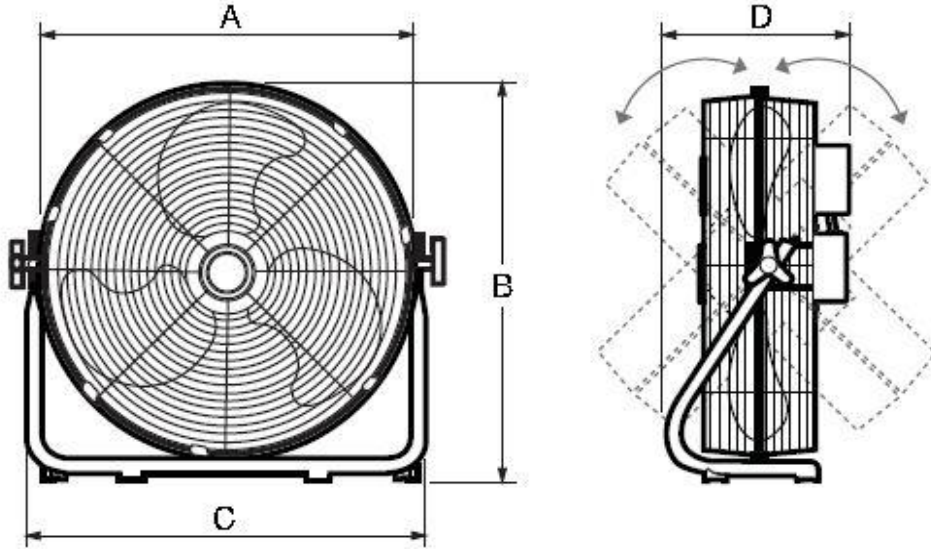

Product Code	A	B	C	D
SPX500	550	605	600	220



Product Code	Speed RPM	Motor Rating (kw)	220-240V / 50Hz / 1Ø		Sound Pressure Levels
			Full Load Current (A)	Speed Controller	
SPX500	950 / 1100 / 1350	0.91 / 0.140 / 0.180	0.39 / 0.60 / 0.80	NO	64 / 58 / 52

Sound pressure levels quoted are average dBA at 3m distance over a sphere, under free field conditions and are presented for comparative purposes only.