

## Mixed Flow EC Fan 150Ø

SJMF150EC mixed flow in-line fan is a truly compact unit occupying the least space with very wide applications.

The fan is built with cold-rolled steel housing and jet-engine design double impellers and equipped with the cutting-edge brushless EC motor.



## SJMF150EC 150Ø

### Greater Air Volume

Due to its up-to-date design in the industry, it works on a much lower power consumption and delivers greater air volume and static air pressure.

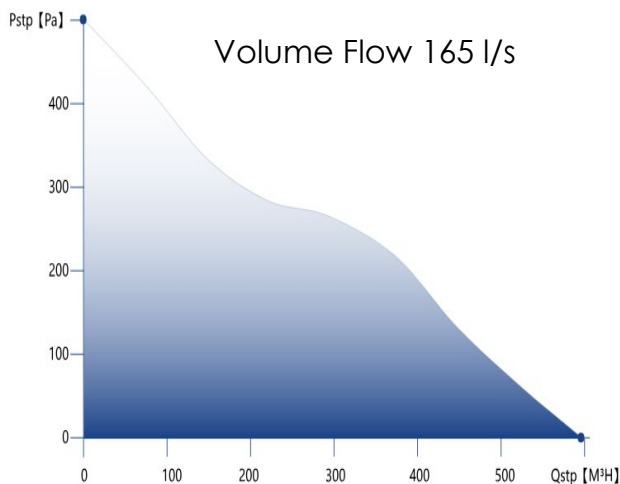

### Heavy Duty

IPX4 protection  
Double heavy duty NMB Ball Bearing  
Cold-rolled steel housing  
Jet engine design double impellers  
Life Expectancy up to 85,000 hours

### Detachable Controller

A Detachable 5 metre lead with a 3.5mm jack connection to unit is supplied for connection to a remote potentiometer, 0-10VDC or PWM Circuit.



### Temperature Range

The fan is designed for use in an ambient temperature of -10°C up to a maximum of +60°C and up to 90% relative humidity. The fan is not suitable for corrosive or explosive atmospheres.

+64 3 365 6278

[www.thehvacshop.co.nz](http://www.thehvacshop.co.nz)

[sales@thehvacshop.co.nz](mailto:sales@thehvacshop.co.nz)

# Mixed Flow EC Fan 150Ø

Wide range of applications  
For both  
Residential & Commercial

Bathroom  
Hydroponics,

Hotels, Factories, Gyms  
Changing Rooms, Toilets  
Bathrooms, Ensuites

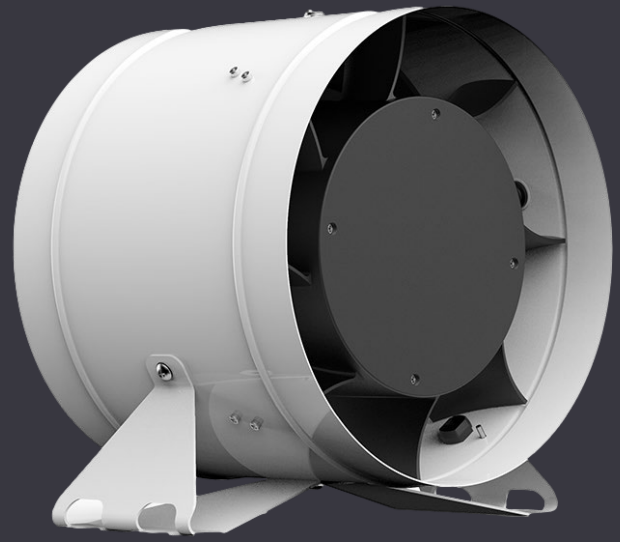

## SJMF150EC 150Ø

## Technical parameters

### Nominal Data

Part Number	SJMF150EC 150Ø
Voltage	110V-120V   220V-240V
Phase (s)	1Ø
Max Power	40Watts
Frequency	50Hz   60Hz
Airflow Maximum	165 l/s
Static Pressure	500 Pa
Maximum Speed	5000 RPM
Noise Level	60 dBA

### Design

Housing Material	Cold Roll Steel
Impeller Design	Mixed Flow
Motor Type	EC Motor
Net Weight	1.6 kg
IP Rating	IPX4

### Dimensions

Diameter	150Ø
Length	155
Overall Height	176mm
Bracket Height	25mm
Controller Size	86x86mm

